

### High Torque Ratings

BVCHAINS RGD Gear coupling; torque capacity exceeds the competition, and it allows smaller coupling size of increased service factor.

### Large Bore Capacity

BVCHAINS Gear couplings can accommodate large shaft diameters for given particular size of coupling compared to the competition, in most instances. That mean you can buy a smaller less expensive coupling and still get the proper rating for the equipment.

### Interchangeability

Complete half coupling assemblies are interchangeable with any other half gear coupling with exposed bolt flange manufactured to AGMA standard. replacement half couplings provide additional hub strength and lower gear mesh loads.

### High Misalignment Capacity

BVCHAINS Gear couplings are designed to accommodate a static misalignment of  $1\frac{1}{2}^{\circ}$  per gear mesh. The recommended operating misalignment is limited to  $3/4^{\circ}$  per gear mesh. Axial moment of connected shafts is also accommodated in these couplings.

### Lubrication System

BVCHAINS Special Grease properties are designed/developed to resist separation of Base oil & thickner due to centrifugal forces encountered in Gear coupling. This benefits for the application -

- Significantly extended relubrication intervals
- Reduced maintenance cost
- Superior lubrication
- Increased coupling life

The location & size lubrication holes in the sleeve ensures that adequate grease is available at the gear mesh, where it is needed must fully moulded seals positively lubricant and seal interior against foreign matter

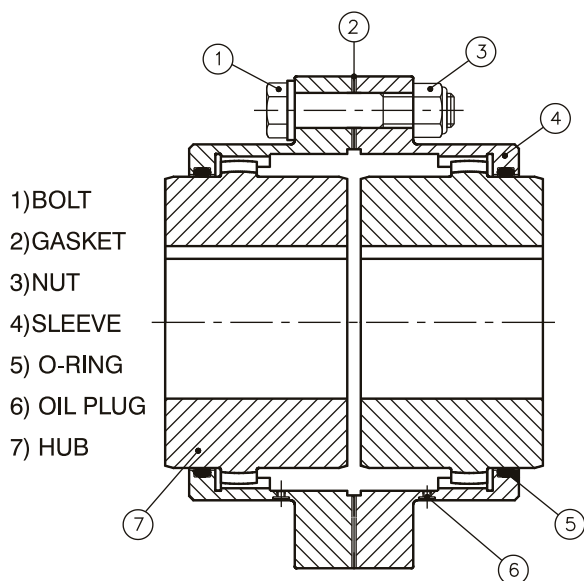

### SERVICE FACTOR - S. F.

Torque Variation	Electric motor gas or steam turbine	Steam engine or Water turbine	Gas or oil Recip. Engine
<b>Consultant Torque</b> e.g. centrifugal pumps and compressors light fans and light duty agitators	1.0	1.25	3.0
<b>Slight Fluctuations</b> e.g. screw compressors & pumps, liquid ring compressors, medium duty mixer & fans	1.5	2.0	3.0
<b>Substantial Fluctuations</b> e.g. reciprocating pumps, heavy duty mixer & fans	2.0	2.5	4.0

### SELECTION :

1. Select appropriate service factor S.F.
2. Calculate coupling Torque T (kNm)

$$T = \frac{9.55 \times P \times S.F.}{N}$$

Where P = Drive rated power (kW)  
N = Speed (rev./min)

3. Select coupling with the same or higher Torque.
4. Check hub bore capacity.
5. Check allowable speed.

# B.V. Transmission Industries

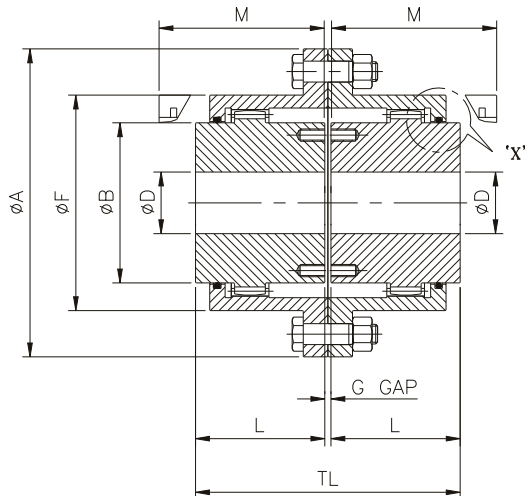

FULL FLEXIBLE TYPE RGD

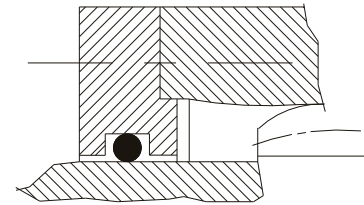

DETAIL 'X'

THIS COVERPLATE CONSTRUCTION FOR SIZES RGD-80 ONWARDS.

### TYPE GD

Size	Coupling Rating		Maximum Speed rpm	Bore Dia ØD mm		Dimensions mm							Solid Hub	
	kW at 100 rpm	Rated Torque Nm		Min. Bore	Max. Bore	ØA	TL	L	ØB	ØF	M	Gap	Mass kg	M.I. (WR <sup>2</sup> ) kg-m <sup>2</sup>
GD-10	14	1337	8000	14	52	116	89	43	69	84	51	3	4.4	0.0052
GD-15	30	2865	6500	22	65	152	103	50	86	105	61	3	9	0.0192
GD-20	53	5061	5600	27	80	178	127	62	105	127	76	3	15	0.041
GD-25	105	10027	5000	32	98	213	159	77	131	155	92	5	27	0.105
GD-30	168	16043	4400	42	115	240	187	91	152	181	106	5	40	0.195
GD-35	231	22059	3900	47	135	279	220	107	178	211	130	6	65	0.454
GD-40	336	32086	3600	47	160	318	248	121	210	250	145	6	96	0.86
GD-45	472	45073	3200	52	180	346	278	135	235	274	165	8	131	1.39
GD-50	650	62070	2900	72	195	389	314	153	254	306	183	8	186	2.53
GD-55	880	84034	2650	72	215	425	344	168	279	334	203	8	247	3.83
GD-60	1205	115069	2450	77	235	457	384	188	305	366	228	8	299	5.21
GD-70	1823	174084	2150	92	280	527	451	221	356	425	266	9	473	11
GD-80	2639	252006	1750	95	285	590	508	249	385	485	300	10	682	20.72
GD-90	3037	290012	1550	100	300	660	565	276	420	535	325	13	898	34.95
GD-100	4100	391521	1450	120	330	711	623	305	470	595	355	13	1242	55.95

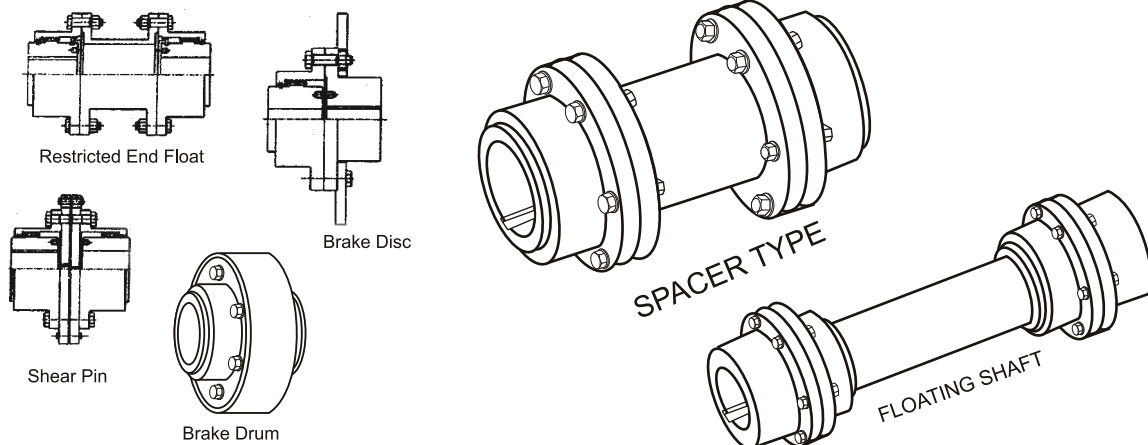

## B.V. Transmission Industries

Unit 18 , Khyati Industrial Estate,  
Laxmi Nagar, Link Road , Goregaon West,  
Mumbai - 400104, Maharashtra , India

Tel : +91- 22-28762345  
Tel : +91- 22-28767941  
☎ : +91- 93247 18035  
☎ : +91- 98206 92004

email :: sales@bvchains.com  
bvchain@gmail.com  
web:: www.bvchains.com

### HALF FLEXIBLE TYPE BGS

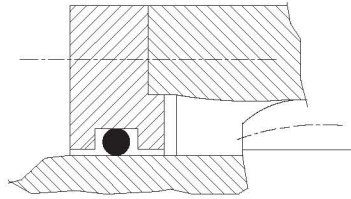

DETAIL 'X'

THIS COVERPLATE CONSTRUCTION FOR SIZES RGS-80 ONWARDS.

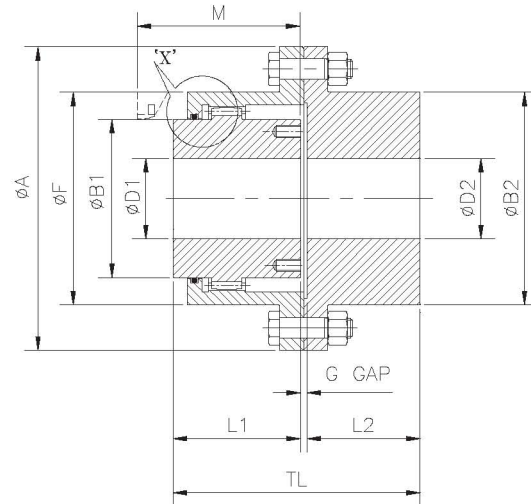

Size	Coupling Rating		Max. Speed rpm	Min Bore Dia mm		Max Bore Dia mm		Dimensions mm								Solid Hub		
	kW at 100 rpm	Rated Torque kNm		Flex Hub	Rigid Hub	Flex Hub	Rigid Hub	øA	TL1	L	øB1	øF	øB2	L2	M	Gap	Mass kg	M.I. (WR <sup>2</sup> ) kg-m <sup>2</sup>
BGS-10	14	1337	8000	14	18	52	60	116	87	43	69	84	84	40	51	4	4.5	0.0055
BGS-15	30	2865	6500	22	26	65	80	152	101	50	86	105	107	47	61	4	9.5	0.0204
BGS-20	53	5061	5600	27	30	80	90	178	125	62	105	127	130	59	76	4	15.5	0.0436
BGS-25	105	10027	5000	32	37	98	110	213	156	77	131	155	157	74	92	5	27.5	0.111
BGS-30	168	16043	4400	42	44	115	130	240	184	91	152	181	182	88	106	5	41.5	0.210
BGS-35	231	22059	3900	47	52	135	150	279	215	107	178	211	212	102	130	6	67	0.477
BGS-40	336	32086	3600	47	52	160	180	318	245	121	210	246	250	116	145	8	100	0.92
BGS-45	472	45073	3200	52	57	180	200	346	274	135	235	274	276	131	165	8	135	1.468
BGS-50	650	62070	2900	72	77	195	220	389	310	153	254	306	309	148	183	9	195	2.73
BGS-55	880	84034	2650	72	77	215	240	425	350	168	279	334	334	173	203	9	261	4.20
BGS-60	1205	115069	2450	77	82	235	260	457	384	188	305	366	366	186	228	10	316	5.70
BGS-70	1823	174084	2150	92	102	280	300	527	452	221	356	425	425	218	266	13	500	12.05
BGS-80	2639	252006	1750	95	105	285	335	590	511	249	385	485	470	249	300	13	715	21.77
BGS-90	3037	290012	1550	100	-	300	370	660	567	276	420	535	518	276	325	15	969	36.60
BGS-100	4100	391521	1450	120	-	330	405	711	626	305	470	595	572	305	355	16	1259	56.27

- The outer dimensions of flanges are rounded up to nearest figure in above tables
- To attend the max. Speed specified above Dynamic balancing is required.
- Max. bores specified above are for uniformly loaded drives only.
- Max. bore for coupling with or equivalent to DIN 6885 keys.
- Min. bore is nothing but a rough stock bore, to which the couplings are manufactured.

## B.V. Transmission Industries

Unit 18 , Khyati Industrial Estate,  
Laxmi Nagar, Link Road , Goregaon West,  
Mumbai - 400104, Maharashtra , India

Tel : +91- 22-28762345  
Tel : +91- 22-28767941  
☎ : +91- 93247 18035  
☎ : +91- 98206 92004

email :: sales@bvchains.com  
bvchain@gmail.com  
web:: www.bvchains.com  
web:: www.jawcouplings.com

Standard full flexible gear coupling TYPE BVG accommodates angular & parallel misalignments or a combination of both as well as axial misalignment (end float). Ideal for all horizontal, close coupled applications including fans, overhead cranes, conveyors, steel & paper mill equipments. One or both the hubs can be easily reversed for more than normal shafts separation applications.

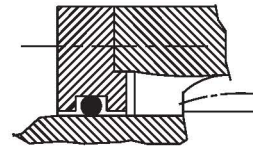
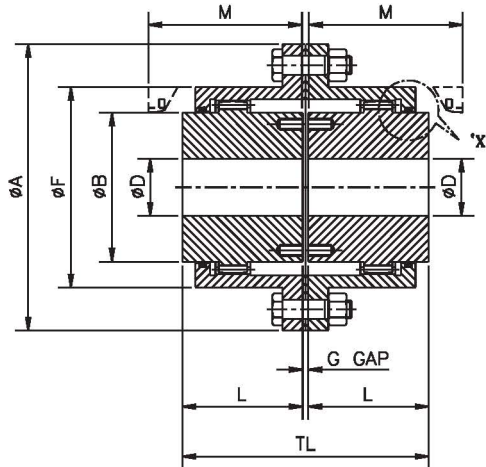

DETAIL 'X'

THIS COVERPLATE CONSTRUCTION FOR SIZES LFG-111 ONWARDS.

### FULL FLEXIBLE TYPE BVG

#### TECHNICAL DATA

Dimensions in MM

Size	kW at 100 rpm	Rated Torque Nm	Max. rpm	Bore ØD		ØA	ØB	ØF	G	L	M	TL	#	
				PB	Max.								Wt. kg	M.I.(WR <sup>2</sup> ) kg-m <sup>2</sup>
BVG -100	6	559	7600	13	35	120	50	75	3	45	54	93	4.1	0.006
BVG -101	12	1127	6730	14	50	170	65	110	5	55	67	115	10.6	0.029
BVG -102	29	2804	6150	20	65	185	85	125	5	70	83	145	15.4	0.046
BVG -103	53	5047	5200	30	80	220	105	150	5	85	103	175	26.0	0.110
BVG -104	100	9557	4580	40	100	250	130	175	5	105	124	215	40.0	0.213
BVG -105	152.94	14605	3950	46	115	290	155	200	10	110	136	230	60.0	0.445
BVG -106	235	22444	3550	50	125	320	175	230	10	125	152	260	84.0	0.745
BVG -107	412	39303	3270	60	145	350	205	260	10	140	174	290	113.4	1.21
BVG -108	529	50472	3015	70	165	380	230	290	10	155	187	320	158.0	2.04
BVG -109	658	62821	2650	80	190	430	250	330	10	165	196	340	210.0	3.46
BVG -110	963	91923	2330	100	230	490	310	390	10	180	216	370	290.0	5.55
BVG -111	1289	123065	2100	110	260	545	350	445	10	200	245	410	545.0	15.25
BVG -112	1723	164516	1940	150	300	590	400	490	10	240	289	490	716.0	24.30
BVG -113	2908	277694	1600	160	330	680	440	555	15	260	312	535	984.0	43.21
BVG -114	4019	383786	1500	200	370	730	500	610	15	280	341	575	1219.0	64.84
BVG -115	4812	459515	1400	230	410	780	540	660	15	320	385	655	1566.0	97.30
BVG -116	7028	671165	1200	260	455	900	625	755	20	350	423	720	2246.0	183.66
BVG -117	9997	954665	1100	300	520	1000	720	855	20	400	489	820	3260.0	338.05
BVG -118	13236	1263938	1000	320	620	1100	810	950	20	450	533	920	4680.0	600.41
BVG -119	17454	1666744	900	300	710	1250	910	1050	30	485	559	1000	6283.0	955.96

## B.V. Transmission Industries

Unit 18 , Khyati Industrial Estate,  
Laxmi Nagar, Link Road , Goregaon West,  
Mumbai - 400104, Maharashtra , India

Tel : +91- 22-28762345  
Tel : +91- 22-28767941  
☎ : +91- 93247 18035  
☎ : +91- 98206 92004

email :: sales@bvchains.com  
bvchain@gmail.com  
web:: www.bvchains.com